

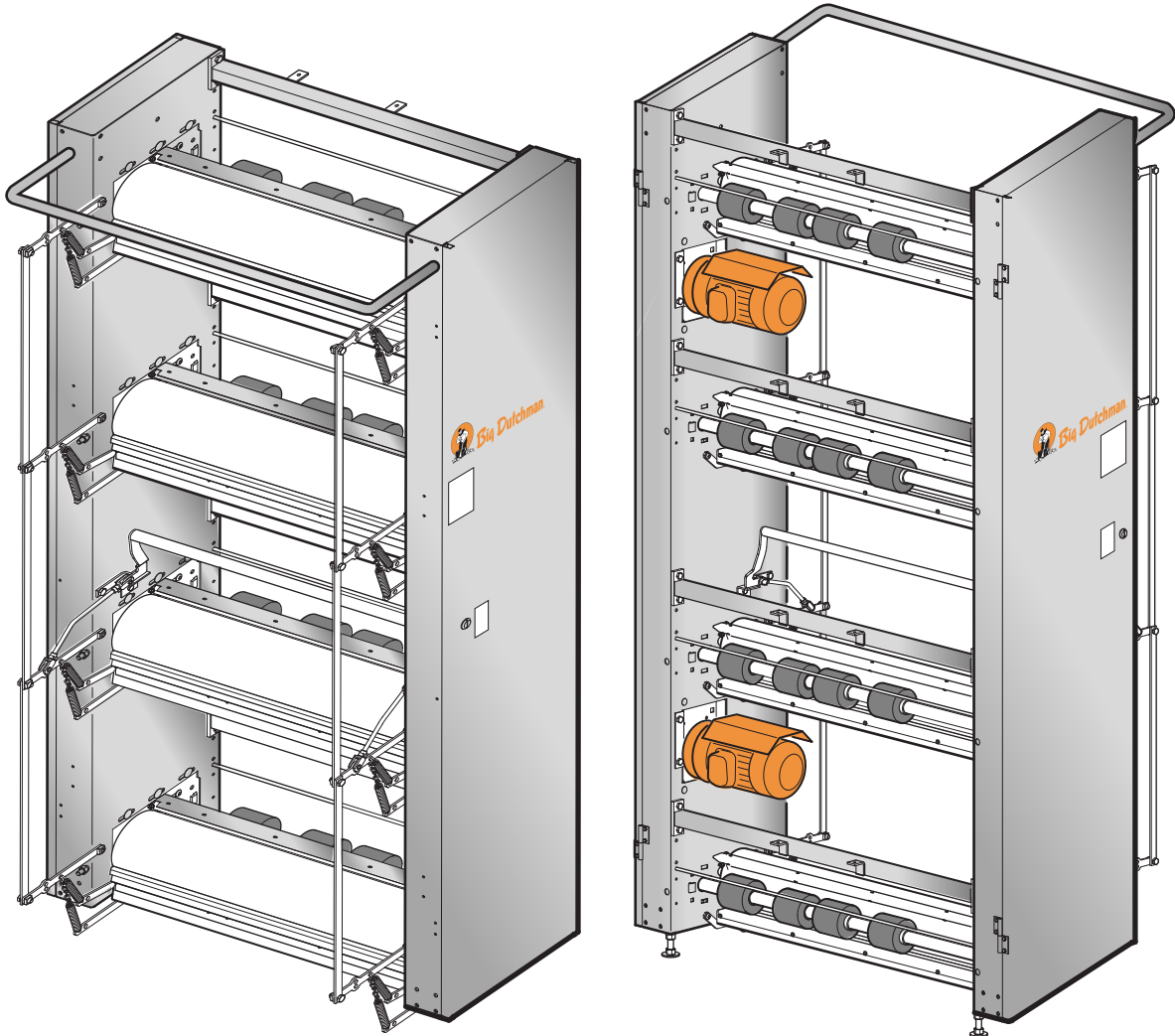

Big Dutchman®



HD2

Manure belt drive

FEATURES AND BENEFITS

Forged drive roller shaft/end cap provides increased drive roller stiffness resulting in higher load capacity and durability.

3/4" Drive sprockets and chain provides increased durability and reliability.

Dual SST/Polyurethane scraper cleaning:

The SST profile maintains uniform pressure across the entire belt. The polyurethane lip prevents tearing / damage to the manure belts. Dual scrapers insure belts stay clean, thereby improving conditions for birds and workers.

Central actuation handle:

The tensioning and release of the scrapers can be easily managed with a single handle for up to 4 tiers.

4 Pressure rollers with central support for pressure roller shaft provides uniform pressure to insure proper tracking of manure belts, especially for longer row lengths.

Manure curtain:

Shower curtain design and turn-lock fasteners allow curtains to be easily opened and closed. Ideal for tunnel ventilation.

Gear motor protection:

Each motor is covered to prevent dust / debris from building up on cooling fins.

M16 x 200 foot assembly:

Designed to withstand the heavy loads during installation and operation.

Dual direction auger:

Dirt is diverted to both sides of the belt resulting in cleaner operation of the idler system.

Auger drive chain:

Auger is driven via chain by the idler roller. The chain assembly is located outside the idler for ease of cleaning and maintenance.



For USA, Canada and South America please contact:

Big Dutchman, Inc. - USA

3900 John F Donnelly Dr • Holland, MI 49424 • USA

tel +1 616 582 4000 • fax +1 616 392 6188

www.bigdutchmanusa.com • info@bigdutchmanusa.com

Details are subject to change: 12/10

86-00-6023